

English version of original German operating instructions

EN

SmartCheck torque tester

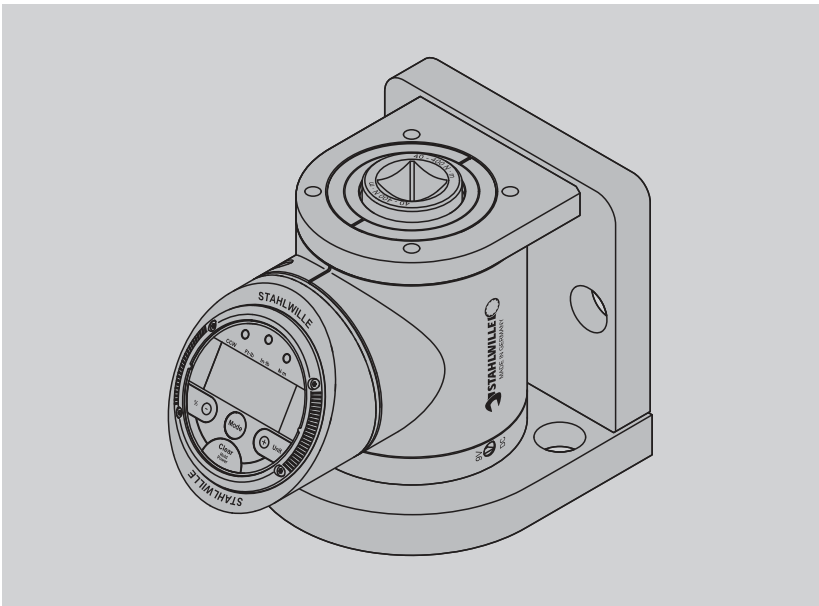

Status: 07/2017



Contents

Notes on the instructions and the manufacturer	5
Availability.....	6
Other applicable documents.....	6
Structural features	6
Safety	7
Structural features of the warning notices.....	7
Structural features of notices referring to material damage	7
Proper use, operating area.....	8
Basic safety instructions.....	8
Avoiding material damage.....	9
Handling batteries and rechargeable batteries	10
Warranty and liability	11
Personnel training	11
Personal safety equipment.....	11
Description	12
Overview of the device	13
Environmental conditions	14
Type plate.....	14
Technical data	15
Transport, scope of delivery, storage	16
Transporting the DPG	16
Scope of delivery.....	16
Storing the DPG	16
Fastening the DPG and preparing for operation	17
Fastening the DPG.....	17
Aligning the display	20



Establishing the current supply.....	21
Operation	25
Operating module	25
Switching the DPG on.....	26
Setting the mode.....	27
Setting the torque unit.....	28
Setting the target torque	29
Setting the torque target zone	30
Resetting the display	32
Resetting the display prior to direction changes.....	33
Overload warning.....	33
Switching the DPG off.....	34
Testing torque wrenches.....	35
Connecting a torque wrench to the DPG.....	35
General measurement of torques.....	37
Testing indicating torque wrenches	38
Testing click type torque wrenches	39
Eliminating faults or malfunctions.....	41
Cleaning	43
Calibrating the DPG	43
Disposal	44
EU declaration of conformity	45

Notes on the instructions and the manufacturer

These operating instructions help you to use the SmartCheck torque tester, abbreviated to DPG in the following, properly, safely and economically.

These instructions are aimed at each person who performs the following activities with and on the DPG:

- Transportation
- Assembly
- Operation
- Cleaning
- Disposal

In particular, these instructions are aimed at trained specialist personnel and qualified and authorised operating personnel.

Each of these persons must have read and understood the contents of these instructions. Compliance with these instructions helps to avoid dangers and to increase the reliability and service life of the DPG. In addition to the notes contained in these instructions, also always observe the legal and other regulations applicable at the installation location, such as e.g.:

- Accident prevention regulations
- Regulations for safe and proper work.



Availability

These instructions are part of the DPG. Always store these instructions along with the documentation on the DPG. Make sure that the instructions are available to the user. Enclose these instructions if you sell the DPG or pass it on in any other manner.

Other applicable documents

Also observe and comply with the information in the other applicable documents. Other applicable documents particularly include the following document types:

- DPG factory calibration certificate
- Operating instructions of the torque wrenches to be tested

Structural features

Defined structural features are assigned to the various elements within the operating instructions. You can therefore easily determine the type of text which this involves:

Normal text,

"BUTTONS" on the DPG

- Lists, first level
 - Lists, second level or
- Action steps.

 Tips. General information and information regarding the economical use of the DPG is provided here.

Safety

Structural features of the warning notices



DANGER

Notices containing the word DANGER warn of hazards which lead directly to severe or fatal injuries.



CAUTION

Notices containing the word CAUTION warn of hazards which may possibly lead to minor to moderate injuries.

Structural features of notices referring to material damage

ATTENTION

Notices containing the word ATTENTION warn of hazards in which property damage may possibly occur.



Proper use, operating area

The SmartCheck type 10, 100, 400 and 800 torque testers are suitable for testing tracking and click type torque wrenches as well as for generally measuring torques.

The SmartCheck type 10S torque tester is exclusively suitable for testing tracking and click type torque screwdrivers.

Use in explosive areas is prohibited.

Proper use also includes observing and compliance with all of the data in these instructions. This particularly applies to observing and compliance with all safety instructions and warning notices as well as the technical limit values. The DPG must only be used by personnel trained in using the DPG.

Any other, or more extensive, use is regarded as improper, and can lead to material damage or personal injury

Basic safety instructions

Avoiding a risk of explosion

Risk of explosion due to use of the DPG in explosive areas.

- Do not use the DPG in explosive areas.

Avoiding electric shock

There is a risk of fatal accident due to electric shock if you ignore the following safety instructions:

- Never open the DPG housing.
- Use only the CE-conformant plug-in power supply unit included in the scope of delivery, see Page 15.
- Prior to cleaning work on the DPG, disconnect the plug-in power supply unit from the DPG.

Avoiding hazards due to improper assembly

If the DPG is not assembled properly, there is a risk of losing the balance weight during testing. This can result in broken bones, bruises and crushing.

- Mount the DPG firmly on a worktop

Avoiding injuries due to incorrect handling

A risk of dropping occurs if an unfastened DPG is handled incorrectly. This can result in broken bones, bruises and crushing.

- Only grip the DPG at the mounting bracket.
- Wear safety shoes with steel toe caps.

Avoiding hearing damage

When testing click type torque wrenches, the triggering impact causes a sound pressure level. This can cause noise-induced hearing loss.

- Wear ear protectors in this case.

Avoiding material damage

The DPG is precision test equipment, and must be handled with the greatest of care. Avoid mechanical, chemical or thermal effects which exceed the stresses involved in proper use.

Soiling or moisture can lead to material damage and influence the measurement accuracy.



Avoid material damage on the DPG and the torque wrenches through the following measures:

- Make sure that the torque wrenches are not damaged.
- Only test the torque wrenches in the manner described in these operating instructions.
- Do not overload the DPG.
- Only use the DPG for testing in the measuring range intended for this.

Handling batteries and rechargeable batteries

Children could swallow the batteries and rechargeable batteries and choke on them.

- Make sure that batteries and rechargeable batteries are kept out of the reach of children.

Batteries and rechargeable batteries may contain poisonous substances which pollute the environment.

- Dispose of batteries and rechargeable batteries according to the applicable legal regulations.

Leaking batteries and rechargeable batteries may cause damage to the DPG.

- If the DPG is not used for a long time, remove the batteries or rechargeable batteries.
- Replace weakening batteries or rechargeable batteries in good time.
- Do not charge batteries.
- Only use batteries or rechargeable batteries according to the data from Page 15.

Warranty and liability

Warranty and liability claims in the event of personal injury and material damage are inadmissible if they are attributable to one or more of the following causes:

- Improper use of the DPG.
- Improper assembly, operation and cleaning of the DPG.
- Non-observance of the notes in the DPG operating instructions.
- Unauthorised modification of the DPG's properties.
- Improperly performed repairs.

Personnel training

- Only personnel which has been trained in handling the DPG or has been familiarised by a trained person may work with the DPG.
- The personnel must be familiar with the application and handling of torque wrenches.
- Personnel undergoing on-the-job training may only work with the DPG under the supervision of an experienced person.

Personal safety equipment

Crushing of feet possible due to a DPG being dropped during lifting and carrying.

- Wear safety shoes with steel toecaps.

Noise-induced hearing loss possible due to the triggering impact of a torque wrench.

- Wear ear protectors.



Description

Description

The SmartCheck type 10, 100, 400 and 800 torque testers are suitable for testing tracking and click type torque wrenches as well as for generally measuring torques.

The SmartCheck type 10S torque tester is exclusively suitable for testing tracking and click type torque screwdrivers.

Use in explosive areas is prohibited.

The DPG has a stable plastic housing. The mounting bracket is made of metal. The holes present in the mounting bracket enable fastening in a vertical or horizontal position. STAHLWILLE recommends fastening in a vertical position, see Page 18.

The transducer is integrated into the plastic housing. Refer to the technical data for the respective measuring range.

The DPG's display deviation is ± 1 %.

Current can be supplied using the power supply unit included in the scope of delivery or with batteries or rechargeable batteries.

Diverse setting options are available to guarantee perfect reading of the display.

Three modes are available:

- Track, for general measurement of torques
- Peak Hold, for indicating torque wrenches
- First Peak, for click type torque wrenches.

Overview of the device

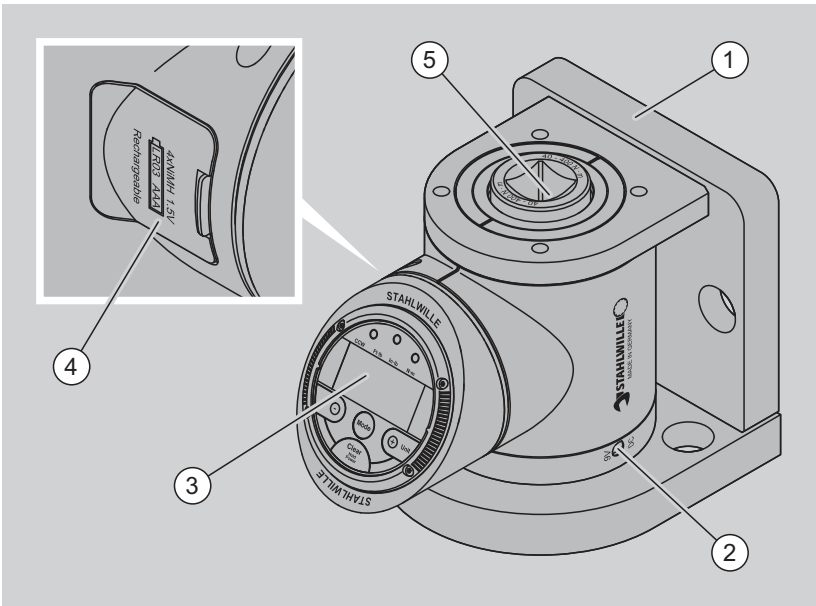

No.	Designation
1	Mounting bracket
2	Connection socket for power supply unit
3	Display, mounted for rotation
4	Battery compartment
5	Recessed square on transducer

Environmental conditions

The ambient temperature during use must lie between $-2\text{ }^{\circ}\text{C}$ and $+60\text{ }^{\circ}\text{C}$.

- Make sure that the DPG can adapt to the prevailing ambient conditions for at least one hour prior to use.

Type plate

The type plate is attached to the DPG's housing. The DPG's nominal value corresponds to the type. The figure shows a type plate for a type 100 DPG (nominal value 100 N·m).

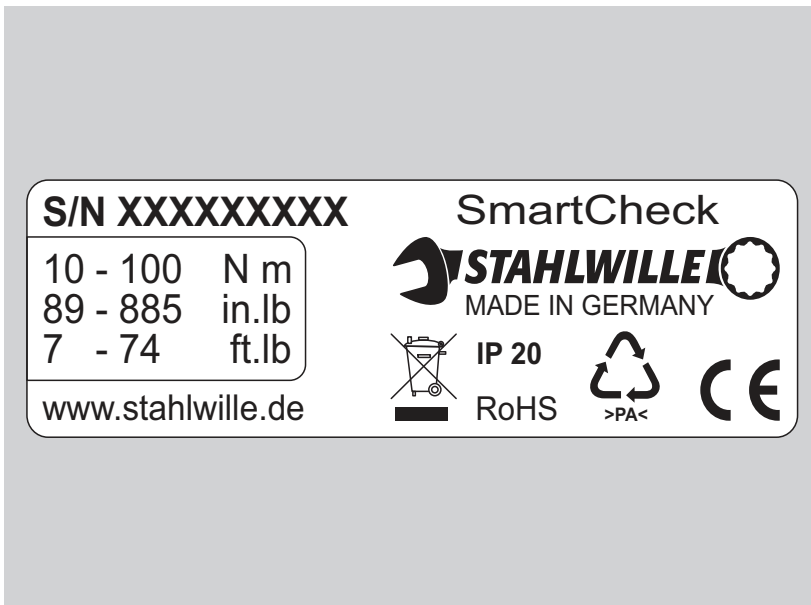

Technical data

Type	10S*, 10	100	400	800
Measuring range				
N·m	1–10	10–100	40–400	80–800
ft·lb	0.74–7.4	7–74	30–295	59–590
in·lb	8.9–88.5	89–885	354–3540	708–7081
Recessed square	1/4"	3/8"	3/4"	3/4"
Width [mm]	120	120	120	120
Height [mm]	124	124	124	124
Depth [mm]	167	167	167	167
Weight [g]	5210	5310	5690	5690

* For checking torque screwdrivers

Plug-in power supply unit:

Input: 110–230 VDC, 50–60 Hz

Output: 9 VDC, jack plug 5 mm/2 mm with (+)

Batteries/rechargeable batteries:

9 V block battery or rechargeable battery or

Four 1.5 V AAA batteries or rechargeable batteries



Transport, scope of delivery, storage

Transporting the DPG

The DPG weighs 5 to 6 kg. Transport the DPG only in the accompanying plastic case, and secure this sufficiently against being dropped during transport.

Scope of delivery

The DPG's scope of delivery includes the following:

- Plastic case incl. inserts
- Torque tester
- Plug-in power supply unit incl. four adapters for different countries
- Factory calibration certificate
- Operating instructions
- Reduction adapter
 - From 3/8" to 1/4" DPG type 100
 - From 3/4" to 1/2" DPG type 400

Storing the DPG

➤ Store the DPG only in the accompanying plastic case.

Ensure the following storage conditions:

- Relative humidity: 20–60%, non-condensing
- Temperature: –20 to +60 °C

Fastening the DPG and preparing for operation

Fastening the DPG

The DPG is suitable for vertical or horizontal installation. Vertical or horizontal refers to the position of the transducer axis.

-  STAHLWILLE recommends fastening the DPG the vertical transducer axis position.

To be able to work with the DPG, it must first be fastened securely. The base must be sufficiently solid, e.g. a worktop. The worktop must be approx. 30 to 50 mm thick.

Use the following for fastening:

- Two cheese head screws with hexagon socket M10 according to ISO 4762, material strength 10.9
 - Two washers
 - Two hexagon nuts M10
-



CAUTION

Broken bones, bruises and crushing during assembly. The DPG can fall down during handling.

- Wear safety shoes with steel toecaps.
-



CAUTION

Risk of injury due to inadequate fastening of the DPG. The DPG can fall down.

- Fasten the DPG securely.
➤ Wear safety shoes with steel toecaps.
-

Fastening the DPG and preparing for operation



To fasten the DPG on a worktop, proceed as follows:

- Drill clearance holes with a diameter of 12 mm in the worktop.
- Bolt the DPG so firmly to the base (70 N·m) using the intended holes that it can absorb stresses caused by the torque values to be tested.
- Secure each of the hexagon socket head screws with a washer and a nut.

Example of vertical fastening:

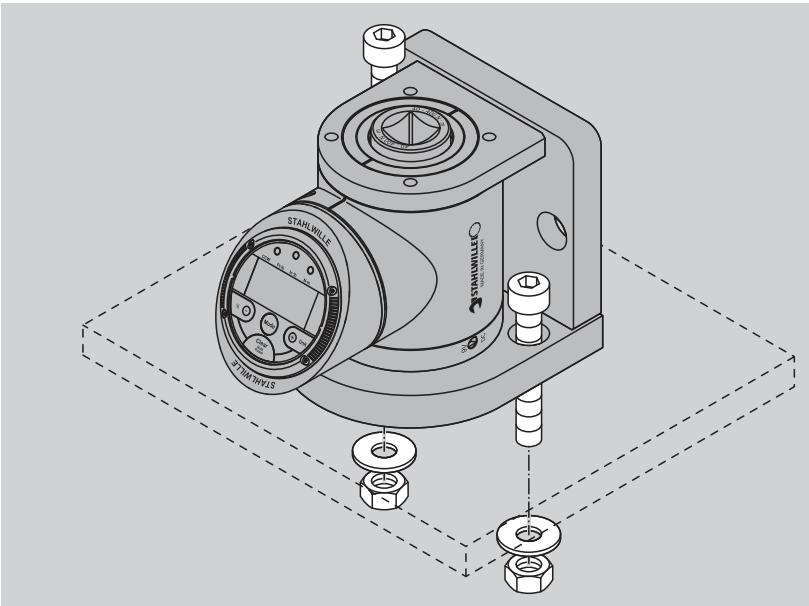

Example of horizontal fastening:

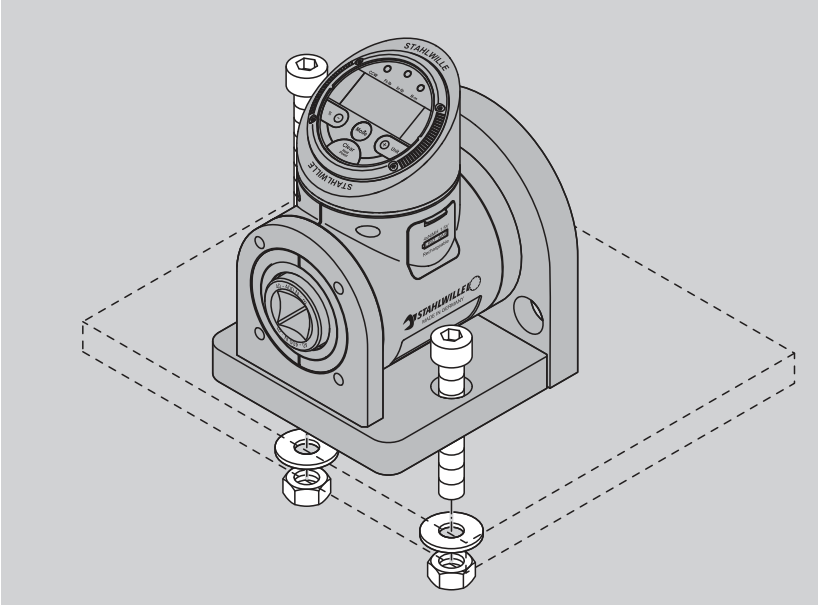

Fastening the DPG and preparing for operation



Aligning the display

To read the display clearly, it can be set as shown in the following for your application.

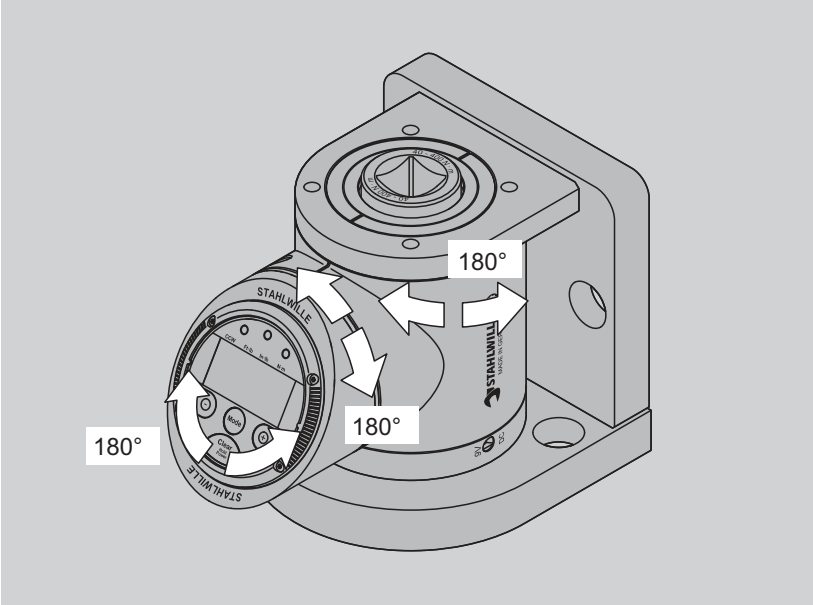

Establishing the current supply

Connecting the power supply unit



DANGER

Danger of electric shock due to the use of an incorrect plug-in power supply unit.

- Use only the plug-in power supply unit included in the scope of delivery.
 - Make sure that the specifications on the plug-in power supply unit model plate correspond to those of the mains connection.
-

- ⓘ The plug-in power supply unit can be connected at any time. After connecting, the current supply is automatically interrupted by any batteries or rechargeable batteries which are inserted.

To connect the plug-in power supply unit, proceed as follows:

- Insert the plug-in power supply unit's jack plug (see Page 15) into the corresponding socket on the DPG.

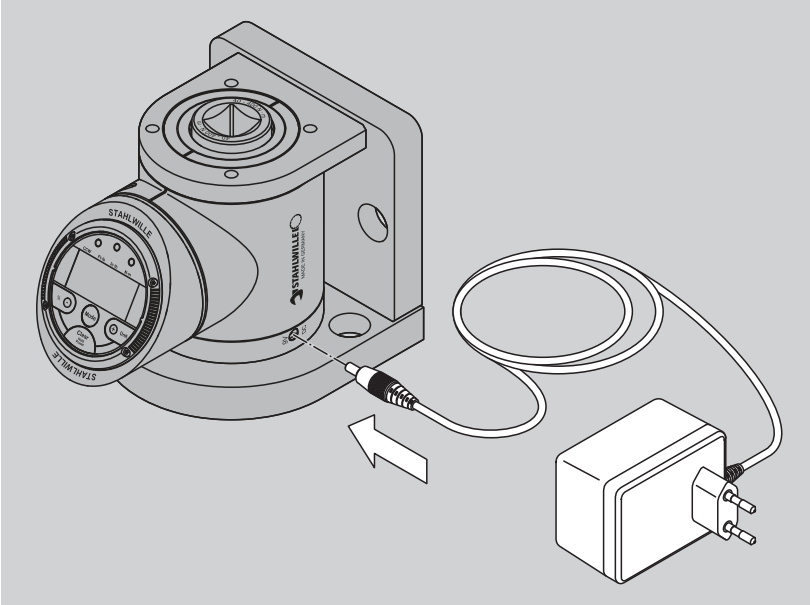

- Connect the plug-in power supply unit to a properly installed and earthed mains socket of 110–240 VDC, 50–60 Hz.

Inserting batteries/rechargeable batteries

- ⓘ The DPG has no charging function for rechargeable batteries. Charge rechargeable batteries with an inadequate state of charge in a separate charger which is suitable for this purpose.

The DPG can be operated with two types of batteries/rechargeable batteries. With either a 9 V block battery or a 9 V rechargeable battery or with four 1.5 V AAA batteries/rechargeable batteries. An adapter for the four AAA batteries/rechargeable batteries is included in the scope of delivery.

To insert a 9 V block battery or a 9 V rechargeable battery, proceed as follows:

- Open the battery compartment cover.
- Connect the connection available in the battery compartment to the terminals of the 9 V block battery or the 9 V rechargeable battery (1.).
- Insert the 9 V block battery or the 9 V rechargeable battery into the battery compartment as shown (2.).
- Make sure that the cable is not trapped.
- Close the battery compartment with the cover.

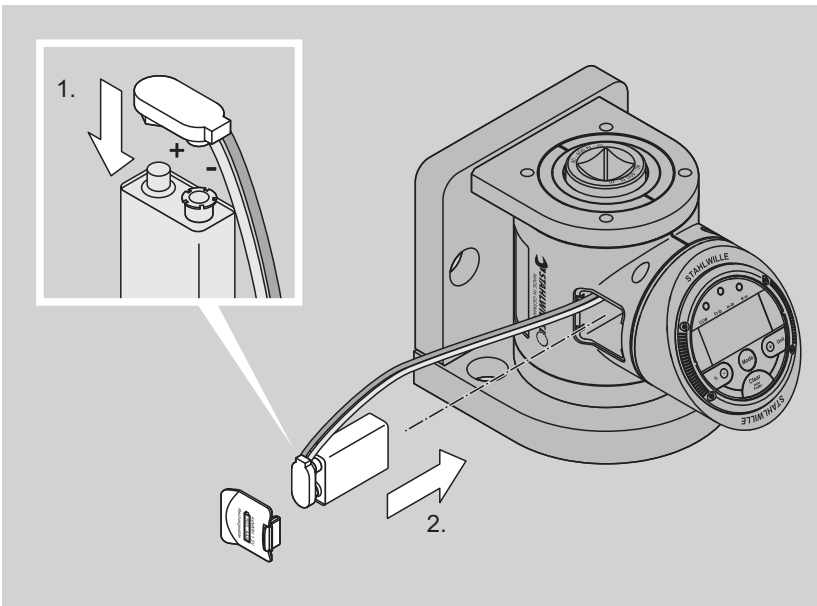

To use the adapter for four 1.5 V AAA batteries/rechargeable batteries, proceed as follows:

- Insert the four 1.5 V AAA batteries/rechargeable batteries into the adapter, connecting the terminals correctly (1.).
- Open the battery compartment cover.
- Connect the adapter connection available in the battery compartment (2.).

Fastening the DPG and preparing for operation



- Insert the adapter into the battery compartment as shown (3.).
- Make sure that the cable is not trapped.
- Close the battery compartment with the cover.

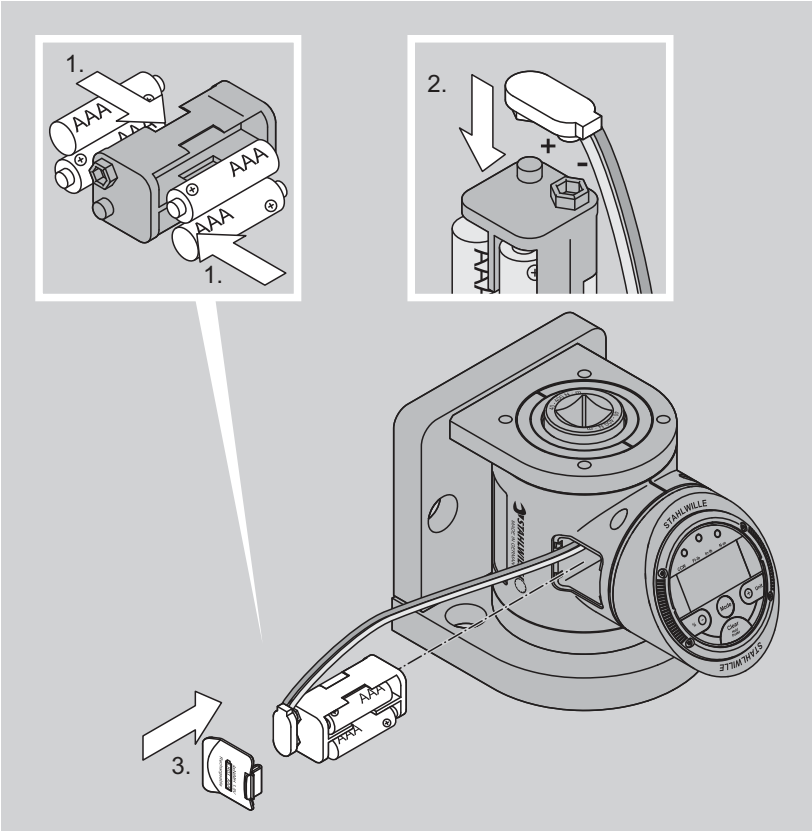

Operation

Operating module

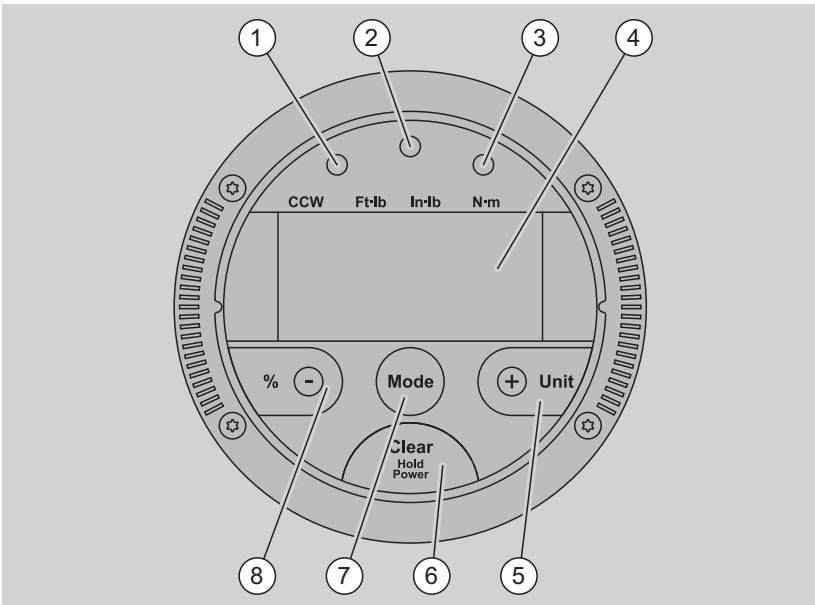

No.	Designation
1	LED yellow, target torque not achieved
2	LED green, target torque achieved (within Tolerance)
3	LED red, target torque exceeded, overload warning
4	Display
5	Display target torque, increase values, select units
6	Switch DPG on or off, reset display, set target zone
7	Mode selection: Track, Peak Hold or First Peak
8	Set tolerance range in % of the target torque, reduce values

Switching the DPG on

To switch the DPG on, proceed as follows:

- Make sure that no torque is applied whilst switching on.
- Press the "CLEAR HOLD POWER" button and keep it pressed for approx. one second.

An audible signal is heard, the LEDs light up once and the display is switched on.

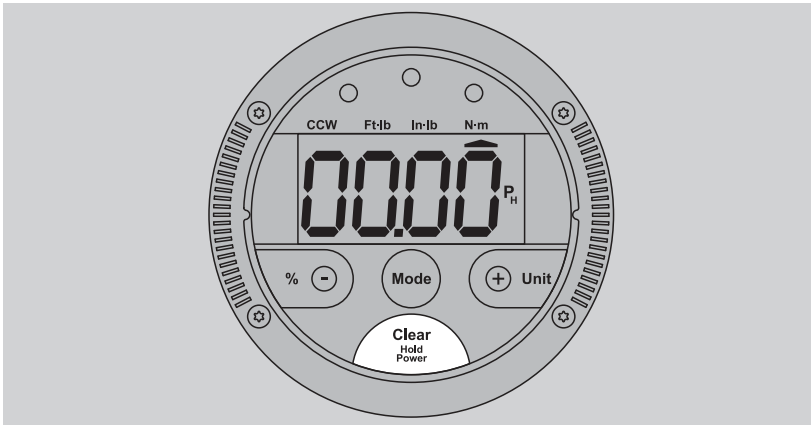

If the batteries' or rechargeable batteries' state of charge is too low, the DPG cannot be switched on, or immediately switches off again.

The settings last used are stored. This also applies if no current supply was available temporarily.

- ⓘ If the DPG is not used, it switches off automatically after approx. three minutes.

Setting the mode

Three modes are available:

- Track, for general measurement of torques
- Peak Hold, for indicating torque wrenches
- First Peak, for click type torque wrenches.

Track mode:

The currently applied torque is shown on the display. The PH display on the right next to the numbers is hidden.

Peak Hold mode:

The highest applied torque is shown on the display. The PH display on the right next to the numbers is visible.

First Peak mode:

The torque on triggering (Click) is shown on the display. FP is shown on the left next to the numbers. The PH display on the right next to the numbers is visible.

To set the desired mode, proceed as follows:

- Press the "MODE" button until the desired mode is shown on the display.

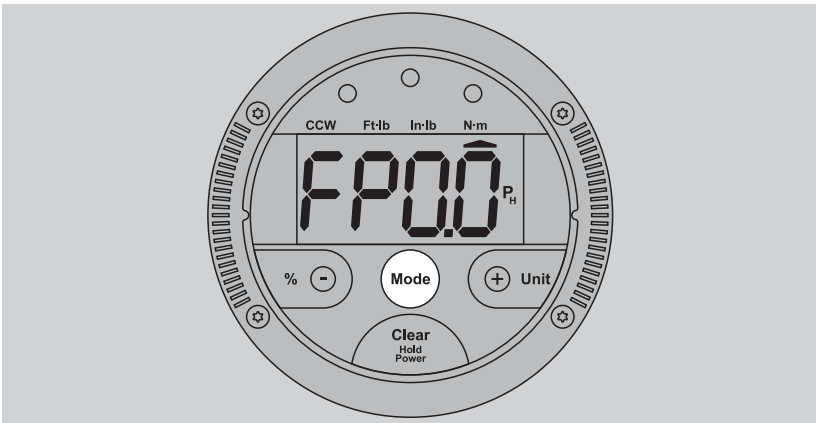

- ⓘ The last setting carried out is stored and is available when the DPG is next switched on.

Setting the torque unit

The following units can be set for the torque:

- N·m
- ft·lb
- in·lb

To set the desired torque unit, proceed as follows:

- Press the "CLEAR HOLD POWER" button and keep it pressed.
- Press the "+" button until the marking at the top of the display points to the corresponding unit.
- Release the buttons.

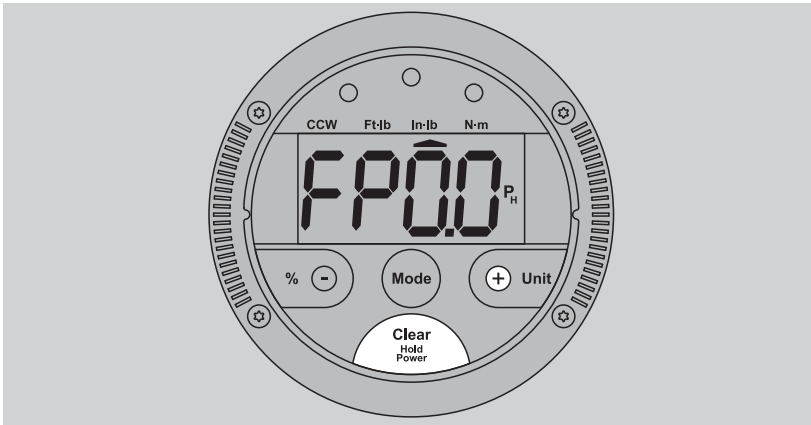

- ⓘ The last setting carried out is stored and is available when the DPG is next switched on.

Setting the target torque

To set the desired target torque, proceed as follows:

➤ Press the "+" or "-" button once.

The currently set target torque is displayed for approx. one second.

➤ Use the "+" or "-" button to set the target torque.

The "+" button is used to increase the target torque.

The "-" button is used to decrease the target torque.

The longer one of the buttons is kept pressed, the faster the value is changed.

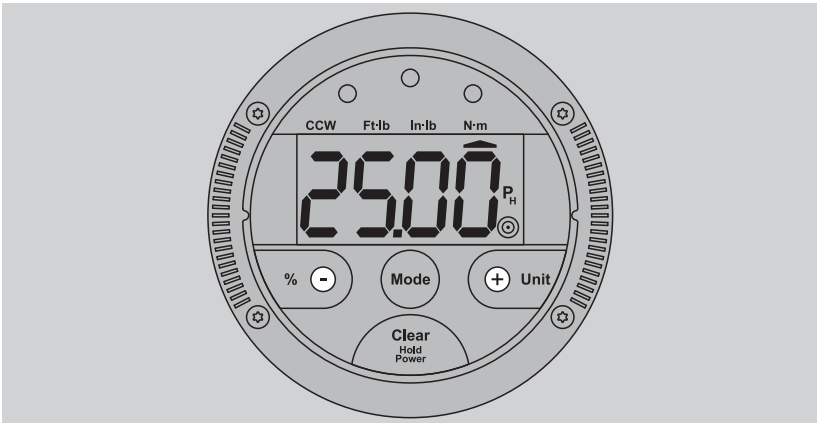

-  The last setting carried out is stored and is available when the DPG is next switched on.

Setting the torque target zone

The target zone enables the torque wrench to be tested in a defined tolerance range. The tolerance range is specified as a percentage e.g. ± 4 %. This percentage refers to the target torque which has been entered. The target torque set on the DPG must be identical to the torque set on the torque wrench.

During the test

The available LEDs are used to show whether the torque wrench has triggered within the target zone.

If the yellow LED lights up after triggering, the lower tolerance range has not been reached. The torque wrench must be readjusted.

If the green LED lights up after triggering and an acoustic signal is heard, the tolerance range has been adhered to. The torque wrench is correctly adjusted.

If the red LED lights up after triggering and an acoustic signal is heard, the upper tolerance range has been exceeded. The torque wrench must be readjusted.

- ① A target zone of 4 % is set as default. The target zone can be set to values between 1 % and 10 %. If you do not want to use this function, it can also be switched off.

To set the desired torque target zone, proceed as follows:

- Press the "CLEAR HOLD POWER" button and keep it pressed.
- Press the "-" button.

The current target zone setting is displayed in %.

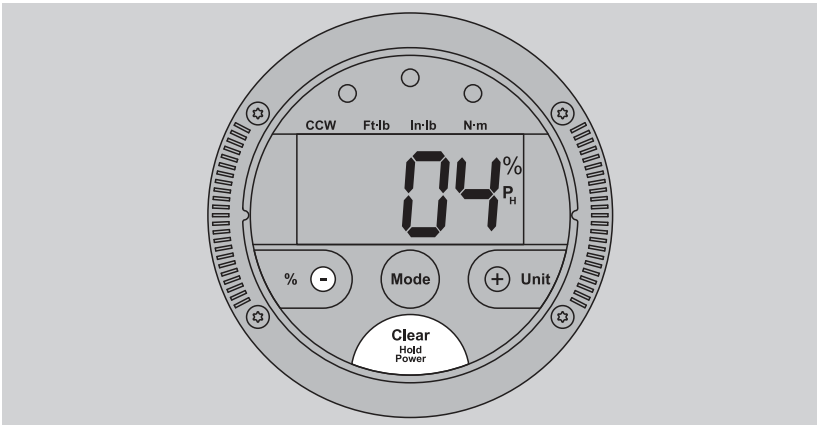

- Press the "-" button until the desired percentage value is reached.

- If you do not want to use this function, select "OFF".

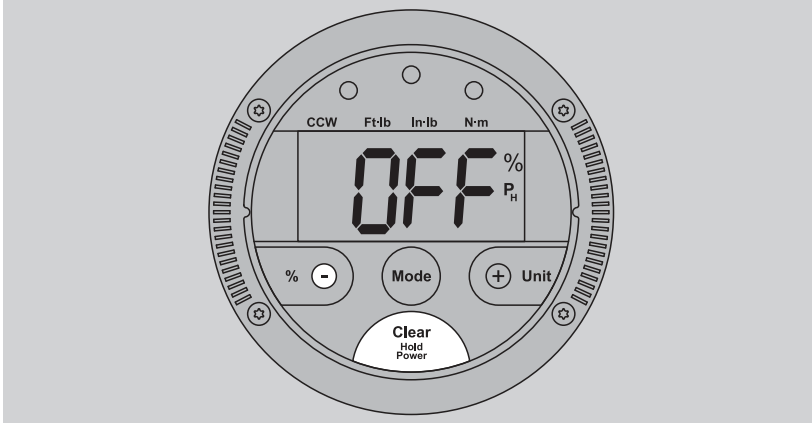

- Release the buttons.

Resetting the display

To reset the DPG's display (to zero it), proceed as follows:

- Press the "CLEAR HOLD POWER" button once.

The display is set to zero.

Alternatively, the display can be reset automatically.

- To do this, remove the torque wrench from the recessed square so that no torque is applied between the tests.

When the torque wrench is inserted back in the recessed square and is actuated, the display is automatically reset and the current torque is displayed.

Resetting the display prior to direction changes

Prior to a direction change, e.g. clockwise/counter clockwise, the DPG must be reset to zero. This increases the accuracy of the test.

To reset the display in the event of direction changes, proceed as follows:

- Apply the DPG's rated torque once in the test direction.
- Relieve the DPG.
- Switch the DPG off.
- Switch the DPG on.

The DPG is tared and is available for tests in the desired direction.

Overload warning

If a torque which exceeds the DPG's measuring range is applied, it can lead to material damage to the DPG. The DPG is therefore equipped with an overload warning function.

If the nominal value is exceeded by more than 10 %, the red LED lights up and an acoustic signal is additionally sounded.

- Immediately abort the test procedure.
- To perform a new test procedure, press the "CLEAR HOLD POWER" button.

Switching the DPG off

To switch the DPG off, proceed as follows:

- Press the "CLEAR HOLD POWER" button until the DPG switches off.

The LEDs light up once.

An audible signal is heard.

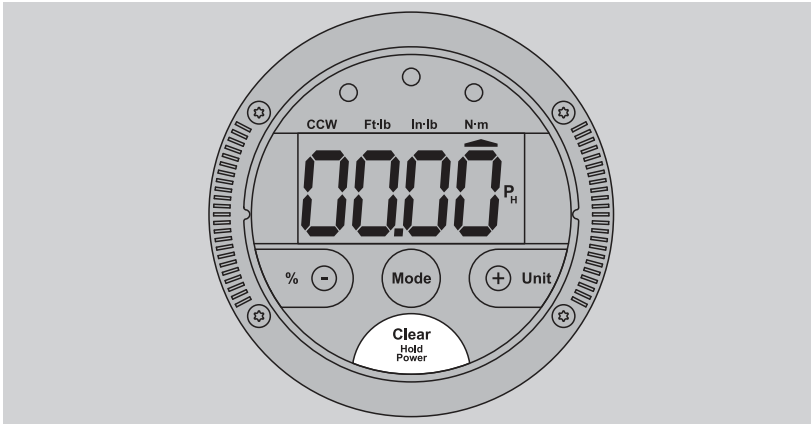

- ⓘ If the DPG is not used, it switches off automatically after approx. three minutes.

Testing torque wrenches

-  Testing torque wrenches is described in the following. The procedure for testing torque screwdrivers with the SmartCheck 10S DPG is similar.



CAUTION

Risk of injury due to incorrect handling of the torque wrenches to be tested.

- Observe and comply with the information in the torque wrench operating instructions.
- In particular, observe and comply with the notes on safe use, the technical limit values and the information on calibration and adjustment.

Connecting a torque wrench to the DPG

If the external square of the torque wrench does not match the recessed square on the DPG, a square adapter can be used. The size of the square adapter is oriented towards the external square of the torque wrench to be tested.



CAUTION

Risk of falling when testing due to incomplete insertion of the external square into the DPG's recessed square.

- Make sure that the recessed square on the DPG is not soiled.
- Insert the external square of the torque wrench to stop into the recessed square on the DPG.

Testing torque wrenches

To connect a torque wrench to the DPG, proceed as follows:

- Make sure that the recessed square on the DPG is not soiled.
- Insert the external square of the torque wrench to stop into the recessed square on the DPG.

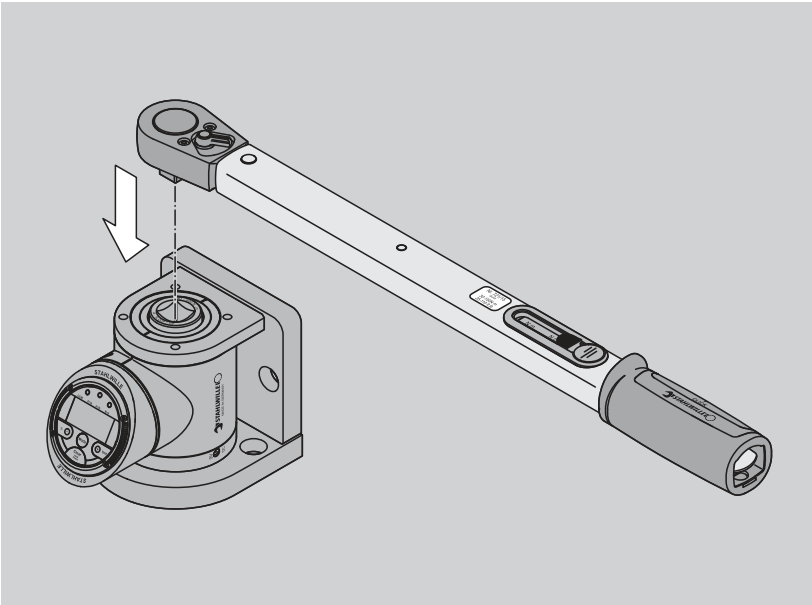

General measurement of torques

To measure a torque in general, proceed as follows:

- Switch the DPG on, see Page 26.
- Set TRACK mode, see Page 27.
- Connect the torque wrench to be tested to the DPG, see Page 35.
- Actuate the connected torque wrench slowly and evenly in the desired direction of rotation and monitor the value shown on the DPG's display.

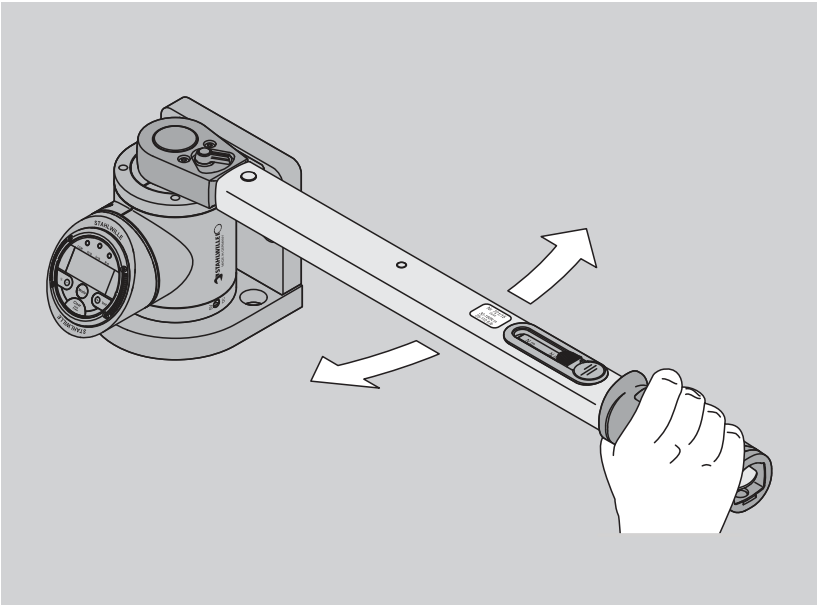

Testing indicating torque wrenches

In the case of indicating torque wrenches, the operator must stop the tightening procedure on reaching the set torque.

To test an indicating torque wrench, proceed as follows:

- Switch the DPG on, see Page 26.
- To set Peak Hold mode, see Page 27.
- Connect the torque wrench to be tested to the DPG, see Page 35.
- Actuate the connected torque wrench slowly and evenly in the desired direction of rotation and monitor the value shown on the DPG's display.
- Check whether the values indicated by the torque wrench match those on the DPG's display.

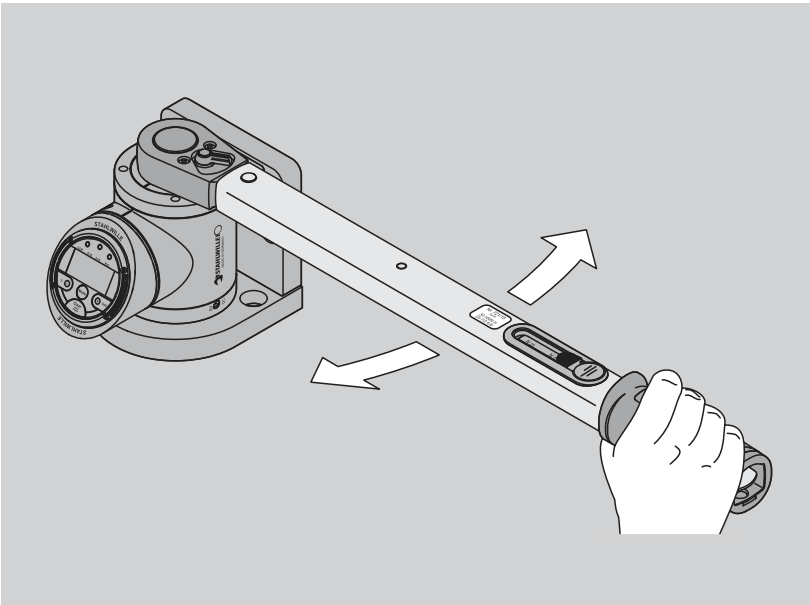

If you have discovered deviations from the nominal values, adjust and calibrate the torque wrench as described in the respective operating instructions, and then test the torque wrench again.

Testing click type torque wrenches

In the case of click type torque wrenches, the tightening procedure is audibly and perceptibly interrupted on reaching the set torque.

To test a click type torque wrench, proceed as follows:

- Switch the DPG on, see Page 26.
 - Set First Peak mode, see Page 27.
 - Make sure that the unit set on the DPG matches the unit set on the torque wrench.
 - Set the desired test value on the torque wrench.
 - Set the target torque on the DPG, see page 29.
 - Connect the torque wrench to be tested to the DPG, see Page 35.
-



CAUTION

Noise-induced hearing loss due to the torque wrench triggering impact during the test.

- Wear ear protectors when testing click type torque wrenches.
-

Testing torque wrenches

- Actuate the connected torque wrench slowly and evenly in the desired direction of rotation until it triggers.
- Check whether the values indicated by the torque wrench match those on the DPG's display.

When a target zone is set, whether the test was successful can be ascertained directly based on the colour of the LED which is lit, see Page 30.

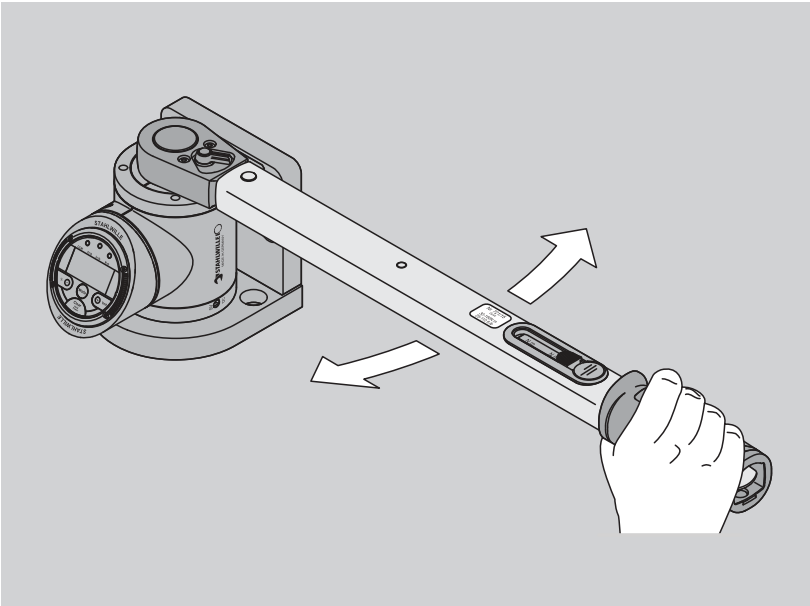

If you have discovered deviations from the nominal values, adjust and calibrate the torque wrench as described in the respective operating instructions, and then test the torque wrench again.

Eliminating faults or malfunctions

Characteristic	Possible cause	Remedy
The DPG cannot be switched on	The batteries are spent.	Exchange the spent batteries/rechargeable batteries for full ones of the same type, see Page 22. or Connect the power supply unit, see Page 21.
The DPG switches off during use	The batteries are spent.	Exchange the spent batteries/rechargeable batteries for full ones of the same type, see Page 22. or Connect the power supply unit, see Page 21.
The DPG does not display a zero value	An excessively high torque has been applied.	Switch the DPG off and on again without applying a torque. If the DPG still displays a torque value, send the DPG to STAHLWILLE service.
The LEDs are functioning but the acoustic signal is not	The selected mode does not support the acoustic signal.	The acoustic signal is only sounded in "Peak" and "First Peak" modes.
Incorrect measurement results in "First Peak" mode	Incorrect handling during the test procedure	Make sure that the wrench is turned carefully and evenly until it triggers. If the torque wrench trigger feels too "soft", set "Peak" mode.



Eliminating faults or malfunctions

Characteristic	Possible cause	Remedy
The LEDs and the acoustic signal are not functioning	No target zone has been set.	Set the target zone, see Page 30.
	The selected mode does not support the visual and acoustic signals.	Make sure that "Peak Hold" or "First Peak" mode is set.

If you are unable to rectify a fault or a malfunction, contact STAHLWILLE service.

Cleaning



DANGER

Danger of electric shock due to moisture when cleaning with the plug-in power supply unit connected.

- Disconnect the plug-in power supply unit from the DPG.
 - Clean the DPG using a dry, clean cloth only.
-



CAUTION

Eye injuries when cleaning with compressed air due to particles of dirt flying around.

- Do not clean the DPG with compressed air.
 - Clean the DPG using a dry, clean cloth only.
-
- Disconnect the plug-in power supply unit from the DPG.
 - Clean the DPG's housing and recessed square using a dry, clean cloth only.

Calibrating the DPG

To guarantee the accuracy of the DPG, it must be calibrated regularly.

- Refer to the enclosed factory calibration certificate for the next calibration date.
- Have the DPG calibrated by STAHLWILLE or a partner certified by STAHLWILLE.

Disposal

Dispose of the DPG through a certified specialist disposal company. Observe and comply with the applicable regulations. If in doubt, contact your municipal or local administration.

The DPG consists primarily of the following materials:

- Steel
- Glass fibre-reinforced plastic PA
- Electronic components

The DPG's electronic components must be disposed of separately.

WEEE registration No.: DE 70431151

WEEE = Waste Electrical and Electronic Equipment



